

Miniature Metal Bellows Coupling

axial pluggable, with expanding clamps

optional
laserwelded
optional full stainless
steel version

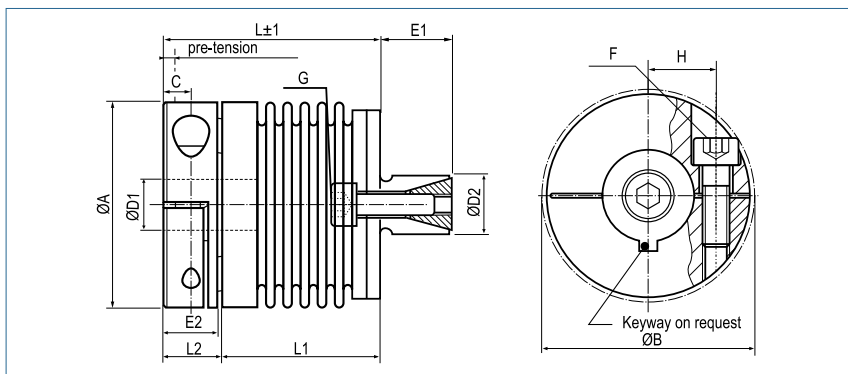

Order Code

KB3P / 15 - 29 - 5 - 10 - D - (S)

Type / Size

Length
L

ØD1
(H7)

ØD2
(f7)

Plug System

Options

Size	Torque TKN (Nm)	Dimensions (mm)								Technical Data							
		L	Ø A	Ø B	D1	D2	H	C	F/G	Mass (g)	Moment of Inertia J (g cm ²)	Spring Stiffness			Misalignment		
		Length	Outer Ø		Bore Size (H7) min~max	(f7) min~max			Screw (ISO4762) TA (Nm)			torsional CT (Nm/rad)	radial CR (N/mm)	axial CA (N/mm)	radial Δ Kr (mm)	axial Δ Ka (mm)	angular Δ Kw (°)
5	0.5	24	15.5	17.5	3-8	8-12	5.2	2.5	M2/M3	14.9	3.4	260	43	13	0.1	0.2	1
		28							15.4	3.6	200	18	10	0.15	0.3	1.5	
		31							15.8	3.7	160	9	8	0.2	0.4	2	
10	1	26	15.5	17.5	3-8	8-12	5.2	2.5	M2/M3	16.4	3.8	510	74	27	0.1	0.2	1
		30							17	4	380	31	20	0.15	0.3	1.5	
		34							17.8	4.2	310	16	16	0.2	0.4	2	
15	1.5	29	20	21	3-10	10-14	7	3	M2.5/M4	31.7	12.8	750	59	15	0.1	0.3	1.5
		7#			0.85/3				34.1	14	700	20	9	0.15	0.4	2	
20	2	33	25	27	3-14	10-16	9	3.5	M3/M4	46.7	29.1	1500	67	12	0.15	0.3	1.5
		39							50.3	33.8	1300	21	11	0.2	0.4	1.5	
		43							57.2	34.9	1050	11	9	0.25	0.5	2	
45	4.5	43	32.5	34	6-16	14-20	12	5	M4/M5	100.7	114.1	6500	168	32	0.1	0.3	1.5
		11#			3.5/5.9				108.1	128	4200	41	20	0.2	0.5	2	
100	10	49	40.5	41.5	6-25	16-22	15.5	5	M4/M6	157.1	273.5	8100	120	27	0.15	0.4	1.5
		59			4.5/10				179.3	339.9	6800	29	17	0.3	0.6	2	



Speed	max. 15000 min ⁻¹
Material	bellows - stainless steel collet clamps - aluminium expanding clamps - steel
Hub	bore tolerance: H7
Temperature Range	-30 °C ~ 120 °C
Keyway	optional acc. DIN 6885 biggest bore marked with a #

