

Typ DMK/LD-FC doppelt gelagert; mit Flanschnabe – Klemmnabe

Synchronkupplung / Durchrastkupplung - spielfrei - mit Rollen

Abmessungen/Dimensions

- øA** = Außendurchmesser / Outer diameter
- øB** = Grundabmessung / Basic dimension
- øC** = Teilkreisdurchmesser / Pitch circle diameter
- øD^{H7}** = Bohrungsdurchmesser / Bore diameter
- øE** = Grundabmessung / Basic dimension
- øF_{g6}** = Zentrierdurchmesser / Enter diameter
- G** = Anschraubbohrung / Fixing bore
- H** = Schrauben / Screws
- J** = Grundabmessung / Basic dimension
- L** = Gesamtlänge / Total length
- L1** = Grundabmessung / Basic dimension
- M** = Maxi male Einschublänge der Welle / Max. shaft rack length
- N** = Grundabmessung / Basic dimension
- O** = Grundabmessung / Basic dimension
- S** = Ausrückweg bei Überlast / Release path at overload



Abmessungen/Dimensions

| Größe Size | øA | øB | øC ±0,1 | øD ^{H7} min- max | øE | øF _{g6} | G 6x Gewinde/Tiefe Thread/Depth | H 1xDIN EN ISO 4762 | J | L | L1 ±1 | M | N | O | S |
|---------------|-----|-----|------------|------------------------------|-----|------------------|--|---------------------------|----|------|----------|----|------|------|-----|
| | mm | | | | | | | | | | | | | | |
| 30 | 65 | 62 | 46 | 12-20 | 55 | 37 | M5 / 7 | M6 | 15 | 59,5 | 44,5 | 30 | 15,5 | 23 | 1,2 |
| 60 | 75 | 70 | 55 | 15-25 | 66 | 42 | M6 / 7 | M8 | 24 | 69,5 | 45,5 | 40 | 15,5 | 23 | 1,2 |
| 150 | 95 | 92 | 78 | 20-35 | 76 | 68 | M6 / 9 | M10 | 26 | 89 | 63 | 45 | 30 | 27 | 2 |
| 200 | 105 | 102 | 86 | 25-40 | 96 | 75 | M6 / 10 | M12 | 30 | 98 | 68 | 50 | 32 | 30 | 2 |
| 300 | 115 | 110 | 90 | 30-45 | 110 | 80 | M8 / 12 | M12 | 30 | 102 | 72 | 50 | 32 | 31,5 | 2 |
| 500 | 129 | 125 | 110 | 35-50 | 110 | 95 | M8 / 12 | M12 | 34 | 106 | 72 | 59 | 30 | 34 | 2 |

Bestellbeispiel / Ordering Example:

DMK/LD-FC

| Typ/Type | Größe/Size | øDH7 | Nm | Version | Schaltart/Functional principle |
|-----------|------------|------|----|---------|--------------------------------|
| DMK/LD-FC | 200 | 32 | 80 | b | C |

Version/Torque range:

- Schaltart/Functional principle: C = Synchronkupplung (360°) = Standard
Single- position re- engagement (360°)
- D = Durchrastkupplung
Multi- position re- engagement
- Nm = Gewünschtes Ausrückmoment
Torque requested

Type DMK/LD-FC double mounted; with flange hub – clamping hub

Single position re-engagement / multi position re-engagement - backlash-free - with roller technology

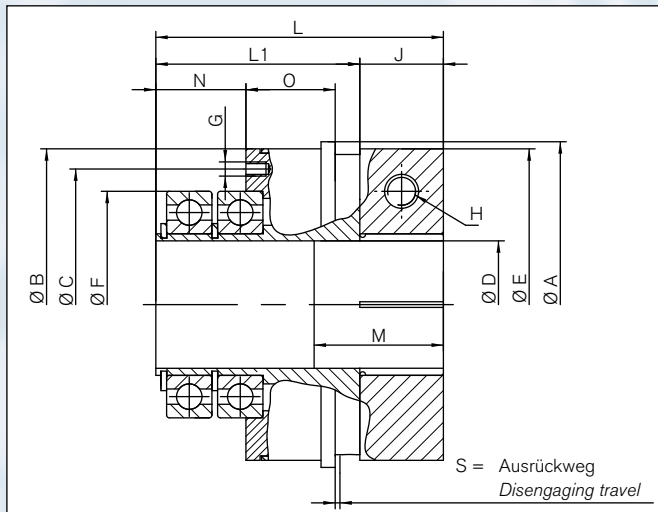

Schnittdarstellung / Sectional view

Technische Daten/Technical Data

- T_{KN}** = Ausrückmoment / Disengagement torque
- n_{max}** = Maximale Drehzahl / Max. rotational speed
- MA** = Anzugsmoment der Spanschrauben / Tightening torque of retaining screws
- J** = Trägheitsmoment / Moment of inertia

Technische Daten/Technical Data

| Größe Size | Einstellbereich / Torque adjustment range | | n _{max} min ⁻¹ | H MA (Nm) | Anflanschseite Flange side | Nabenseite Hub side | Gewicht Weight m kg |
|---------------|---|---------------------|---------------------------------------|-------------------|--|--|------------------------------|
| | Version a (Nm) | Version b (Nm) | | | J 10 ⁻³ Kgm ² | J 10 ⁻³ Kgm ² | |
| 30 | 5-20 | 15-35 | 9240 | 15 | 0,11 | 0,21 | 0,55 |
| 60 | 12-35 | 20-70 | 8185 | 40 | 0,24 | 0,42 | 1,05 |
| 150 | 25-75 | 65-150 | 6230 | 60/55 | 0,8 | 1,16 | 1,8 |
| 200 | 50-120 | 80-200 | 5620 | 100/80 | 1,18 | 1,95 | 2 |
| 300 | 30-140 | 100-300 | 5610 | 110/90 | 1,8 | 2,8 | 2,9 |
| 500 | 140-350 | 250-500 | 4585 | 145 | 2,3 | 7,2 | 4,4 |