

Typ DMK/E-CO mit Klemmnabe – Außenkonus

Synchronkupplung / Durchrastkupplung – spielfrei - mit Rollen

Abmessungen/Dimensions

- øA** = Außendurchmesser / Outer diameter
- øA1** = Grundabmessung / Basic dimension
- øB** = Grundabmessung / Basic dimension
- øC** = Grundabmessung / Basic dimension
- øD1 H7** = Bohrungsdurchmesser / Bore diameter
- øD2 H7** = Bohrungsdurchmesser / Bore diameter
- E** = Einbaumaß für Elastomerstern
Mounting dimension for elastomeric spider
- H1** = Schraube / Screw
- H2** = Schrauben / Screws
- J** = Grundabmessung / Basic dimension
- L** = Gesamtlänge / Total length
- L1** = Grundabmessung / Basic dimension
- L2** = Grundabmessung / Basic dimension
- M1** = Maximale Einschublänge der Welle / Max. shaft rack length
- M2** = Maximale Einschublänge der Welle / Max. shaft rack length
- S** = Ausrückweg bei Überlast / Release path at overload

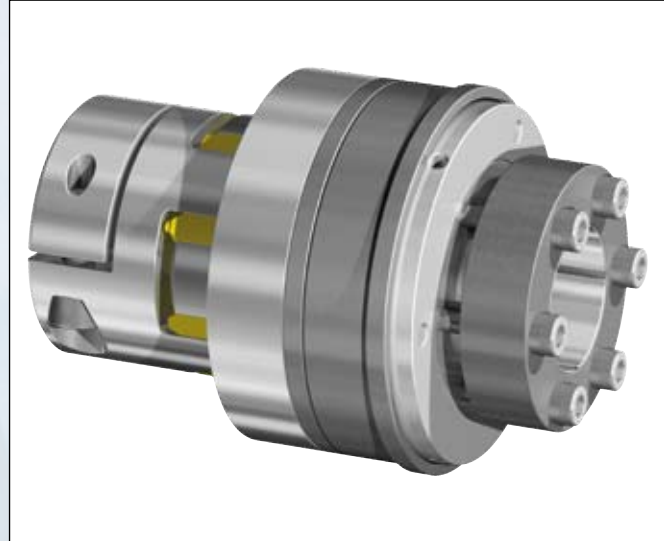

Abmessungen/Dimensions

Größe Size	øA	øA1	øB	øC	øD1 ^{H7}		E	H1		J	L	L1	L2	M1	M2	S
					min- max	min- max		1xDIN EN ISO 4762	6xDIN EN ISO 4762							
mm																
30	65	42	62	45	12-24	12-20	18	M5	M4	22	106,5	28	26,5	26,5	30	1,2
60	75	50	70	55	10-28	15-25	18	M6	M5	23	117	30	30	30	38	1,2
150	95	62	92	65	14-38	20-35	20	M8	M6	30	138	35,5	35	21,5	40	2
300	115	76	110	80	15-45	30-45	24	M8	M8	30	160,5	38,7	45	31	50	2
500	129	85	128	105	25-55	35-50	28	M8	M8	36	183,5	44	56,5	38	53	2

Bestellbeispiel / Ordering Example:

DMK/E-CO

Typ/Type	Größe/Size	ØD1 ^{H7}	ØD2 ^{H7}	Nm	Version	Schaltart/Functional principle
DMK/E-CO	150	35	30	120	b	C

Version/Torque range:

- Schaltart/Functional principle:**
- C = Synchronkupplung (360°) = Standard
Single- position re- engagement (360°)
 - D = Durchrastkupplung
Multi- position re- engagement
 - Nm = Gewünschtes Ausrückmoment
Torque requested

Type DMK/E-CO with clamping hub – outer cone hub

Single position re-engagement / multi position re-engagement - backlash-free - with roller technology

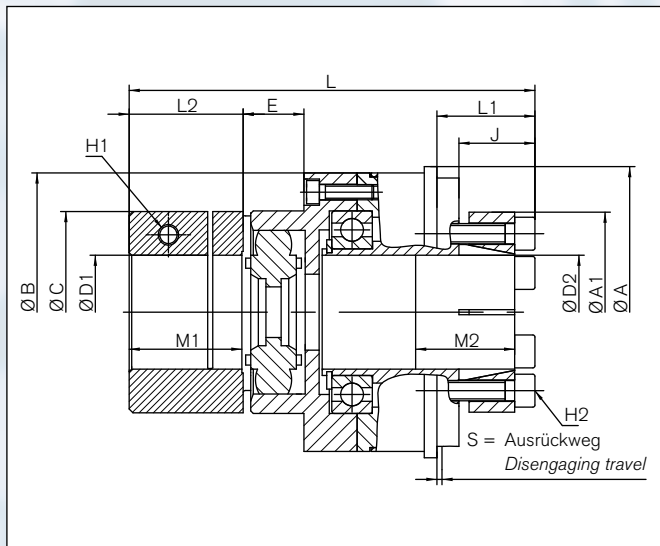

Schnittdarstellung / Sectional view

Technische Daten/Technical Data

- T_{KN}** = Ausrückmoment / Disengagement torque
- n_{max}** = Maximale Drehzahl / Max. rotational speed
- M_A** = Anzugsmoment der Spanschrauben / Tightening torque of retaining screws
- J** = Trägheitsmoment / Moment of inertia
- ΔK_r** = Maximal zulässiger Versatz radial / Max. approved misalignment radial
- ΔK_a** = Maximal zulässiger Versatz axial / Max. approved misalignment axial
- ΔK_w** = Maximal zulässiger Versatz winklig / Max. approved misalignment angular

Technische Daten/Technical Data

Größe Size	Einstellbereich / Torque adjustment range		n _{max} min ⁻¹	H1	H2	Elastomerseite Elastomer spider side	Nabenseite Hub side	Gewicht Weight
	Version a	Version b		M _A Nm	J	10 ⁻³ Kg ^{m²}	10 ⁻³ Kg ^{m²}	
	T _{KN} Nm							
30	5-20	15-35	8950	15	5	0,036	0,1	0,5
60	12-35	20-70	7000	40	8,5	0,15	0,32	1,4
150	25-75	65-150	6000	60	14	0,33	0,8	2,8
300	30-140	100-300	5000	90	18	1,04	3	4,6
500	140-350	250-500	3600	145	26	3,1	5	7,5