

Typ DMK/B-CC mit Klemmnabe – Klemmnabe

Synchronkupplung / Durchrastkupplung - spielfrei - mit Rollen

Abmessungen/Dimensions

- øA = Außendurchmesser / Outer diameter
- øA1 = Grundabmessung / Basic dimension
- øB = Grundabmessung / Basic dimension
- øB1 = Metallbalgdurchmesser / Metal bellows diameter
- øC = Grundabmessung / Basic dimension
- øD1 ^{H7} = Bohrungsdurchmesser / Bore diameter
- øD2 ^{H7} = Bohrungsdurchmesser / Bore diameter
- H1 = Schraube / Screw
- H2 = Schrauben / Screws
- J = Grundabmessung / Basic dimension
- L = 1) Gesamtlänge / Total length
- L1 = Grundabmessung / Basic dimension
- L2 = Grundabmessung / Basic dimension
- M1 = Maximale Einschublänge der Welle / Max. shaft rack length
- M2 = Spannlänge der Welle / Shaft clamping length
- S = Ausrückweg bei Überlast / Release path at overload
- T = Grundabmessung / Basic dimension

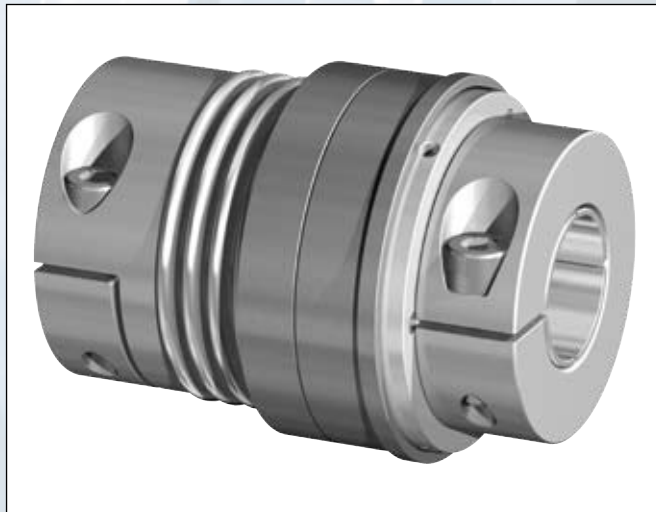

Abmessungen/Dimensions

Größe Size	øA	øA1	øB	øB1	øC	øD1 ^{H7}		øD2 ^{H7}		H1 1xDIN ISO 4762	H2 1xDIN EN ISO 4762	J	L ±2 4/6 ¹⁾	L1	L2	M1	M2	S	T
						Min- Max	Min- Max	mm	mm										
30	65	55	62	56	55	10-25	12-20	M6	M6	15	85 / 93	21	44	24,5	30	1,2	8		
60	75	66	70	66	64	14-35	15-25	M8	M8	24	103 / 114	31	54	29	40	1,2	10		
150	95	76	92	82	80	20-40	20-35	M10	M10	26	126 / 138	32	68	33	45	2	12		
200	105	96	102	90	90	25-42	25-40	M12	M12	30	138 / 150	36	75	37,5	50	2	13		
300	115	110	110	110	110	32-45	30-45	M12	M12	30	136 / 147	38	70	37,5	50	2	13		
500	129	110	125	122	119	40-60	35-50	M14	M14	34	152 / 163	42	82	41	59	2	15		

Bestellbeispiel / Ordering Example:

DMK/B-CC

Typ/Type	Größe/Size Länge/Length	øD1 ^{H7}	øD2 ^{H7}	Nm	Version	Schaltart/Functional principle
DMK/B-CC	200/150	35	30	120	b	C

Version/Torque range:

- Schaltart/Functional principle:
- C = Synchronkupplung (360°) = Standard
Single-position re-engagement (360°)
 - D = Durchrastkupplung
Multi-position re-engagement
 - Nm = Gewünschtes Ausrückmoment
Torque requested

Type DMK/B-CC with clamping hub – clamping hub

Single position re-engagement / multi position re-engagement - backlash-free - with roller technology

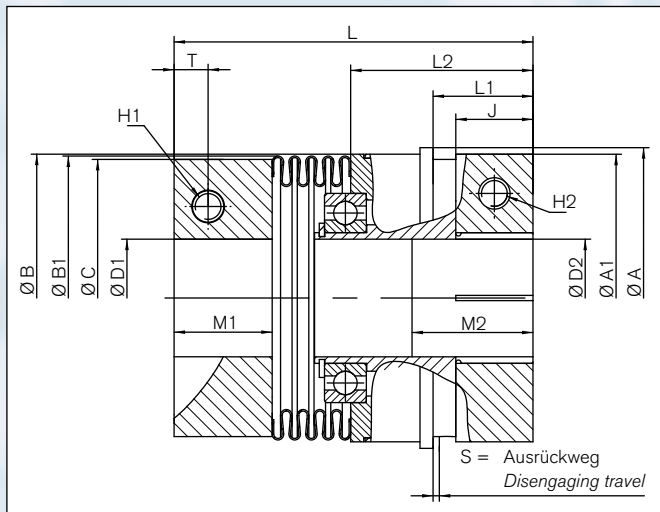

Schnittdarstellung / Sectional view

Technische Daten/Technical Data

- T_{KN}** = Ausrückmoment / Disengagement torque
- n_{max}** = Maximale Drehzahl / Max. rotational speed
- C_r** = Radiale Federsteife / Radial spring stiffness
- C_a** = Axiale Federsteife / Axial spring stiffness
- C_{tdyn}** = Drehfedersteife / Dynamic torsional stiffness
- M_A** = Anzugsmoment der Spannschrauben
Tightening torque of retaining screws
- J** = Trägheitsmoment / Moment of inertia
- ΔK_r** = Maximal zulässiger Versatz radial
Max. approved misalignment radial
- ΔK_a** = Maximal zulässiger Versatz axial
Max. approved misalignment axial
- ΔK_w** = Maximal zulässiger Versatz winklig
Max. approved misalignment angular

Technische Daten/Technical Data

Größe Size	Einstellbereich / Torque adjustment range		n _{max} min ⁻¹	4/6 ¹⁾			H1	H2	Metallbalgseite Metal bellows side	Nabenseite Hub side	Gewicht Weight
	Version a	Version b		C _r N/mm	C _a	C _{tdyn} 10 ³ Nm/rad	M _A Nm	J			
	Nm	Nm							10 ⁻³ Kgm ²	10 ⁻³ Kgm ²	
30	5-20	15-35	9240	718/222	48/27	36/26	15	15	0,16	0,16	0,7
60	12-35	20-70	8183	1125/333	91/53	73/49	35	40	0,4	0,4	1,4
150	25-75	65-150	6830	2030/601	147/86	151/101	70	60	1,5	1,5	2,4
200	50-120	80-200	5620	1531/450	147/85	173/116	90	90	1,65	1,65	3
300	30-140	100-300	5210	6328/1470	284/153	499/280	100	100	3,25	3,25	5,3
500	140-350	250-500	4585	8800/972	105/88	680/310	145	145	3,8	3,8	6,2

1) Die Länge des Balgs beeinflusst die Baulänge L. Es werden zwei Metallbalgausführungen (4 = kurzer Balg mit 4 Wellen; 6 = langer Balg mit 6 Wellen) mit unterschiedlichen Drehsteifen angeboten. Dadurch ändert sich das Längenmaß. / Length of the bellows influences installation length L. We offer two different versions of metal bellows (4 = short bellows with 4 ripples, 6 = long bellows with 6 ripples) with different torsional stiffnesses. Consequently length dimensions variable.