

Typ DCM/D-FK mit Flansch – Passfedernabe

Durchrastkupplung

Abmessungen/Dimensions

- øA** = Außendurchmesser / Outer diameter
- øA1** = Grundabmessung / Basic dimension
- øC** = Teilkreisdurchmesser / Pitch circle diameter
- øD^{H7}** = Bohrungsdurchmesser / Bore diameter
- øF** = Grundabmessung / Basic dimension
- G** = Anschraubbohrung / Fixing bore
- G1** = Maximale Einschraubtiefe / Max. screw-in depth
- H** = Grundabmessung / Basic dimension
- H1** = Grundabmessung / Basic dimension
- K** = Schraubenkopfhöhe / Screw head length
- L** = Gesamtlänge / Total length
- L1** = Maximale Einschublänge der Welle / Max. shaft rack length
- N^{P9}** = Nutbreite / Groove width
- N1** = Nuttiefe / Groove depth
- N2** = Grundabmessung / Basic dimension
- P** = Grundabmessung / Basic dimension
- S** = Ausrückweg bei Überlast / Release path at overload



Abmessungen/Dimensions

Größe Size	øA	øA1	øC	øD ^{H7} min- max	øF	G	G1	H	H1	K	L ±1	L1	N ^{P9}	N1	N2	P	S	mm	
20	55	50	48	8-20	41	6xM5	6,5	5,5	8,4	x	38,5	34,5	6	3,1	4	9	1,4		
50	82	72	70	11-25	60	6xM5	8	7	12	1,3	52	48	6	3,1	4	9	2,3		
100	100	90	89	15-35	78	6xM6	10	7	14	3,0	61	56	8	3,6	5	9	2,6		
200	120	112	105	19-45	91	6xM8	12	10	21	5,5	78	73	10	4,1	5	9	2,6		
400	146	140	125	25-55	105	6xM10	16	11	27	5,5	99,5	93	12	4,1	6,5	9	3,7		
700	176	170	155	30-65	121	6xM12	17	12	33	5,5	113,5	107	14	4,6	6,5	9	4,6		
1200	200	190	160	40-75	136	6xM12	19	11	38	16	119	112	16	5,1	7	9	5		

Bestellbeispiel / Ordering Example:

DCM/D-FK

Typ/Type	Größe/Size	øDH7	Nm	Version	Schaltart/Functional principle
DCM/D-FK	200	30	80	b	D

Version/Torque range:

a, b oder/ or c

Schaltart/Functional principle:

immer D=Durchrastkupplung

always D=Multi- position re- engagement

Type DCM/D-FK with flange – keyway hub

Multi position re-engagement coupling

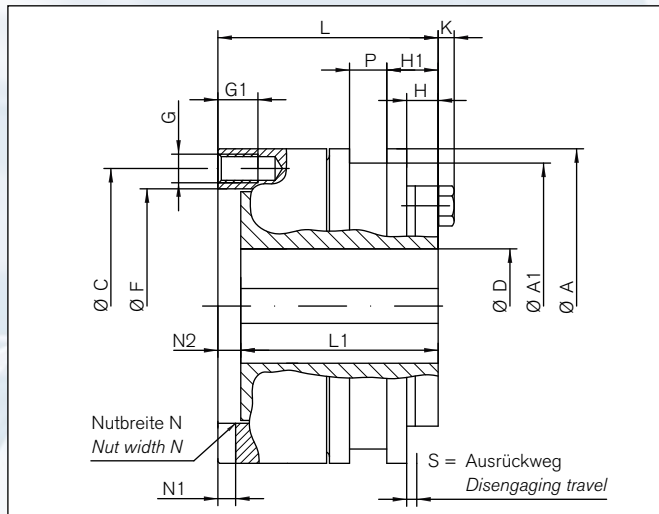

Schnittdarstellung / Sectional view

Technische Daten/Technical Data

- T_{KN}** = Ausrückmoment / Disengagement torque
- n_{max}** = Maximale Drehzahl / Max. rotational speed
- J** = Trägheitsmoment / Moment of inertia

Technische Daten/Technical Data

Größe Size	Einstellbereich / Torque adjustment range			Version a	Version b	Version c	Druckflanschseite Compression flange side	Nabenseite Hub side	Gewicht Weight
	Version a	Version b	Version c						
		T _{KN}			n _{max}			J	
		Nm			min ⁻¹		10 ⁻³ Kgm ²	10 ⁻³ Kgm ²	m
									kg
20	2,5-5	5-10	10-20	4300	4300	2150	0,09	0,1	0,5
50	6-12	12-25	25-50	2880	2880	1440	0,62	0,67	1,5
100	12-25	25-50	50-100	2360	2360	1180	1,49	1,9	2,7
200	25-50	50-100	100-200	2000	2000	1000	3,8	5,17	4,7
400	50-100	100-200	200-400	1660	1660	830	10	16,31	9,8
700	87-175	175-350	350-700	1360	1360	680	23,5	41,62	16
1200	150-300	300-600	600-1200	1200	1200	600	39,61	76,89	21