

DECELERATORI IDRAULICI SHOCK ABSORBERS

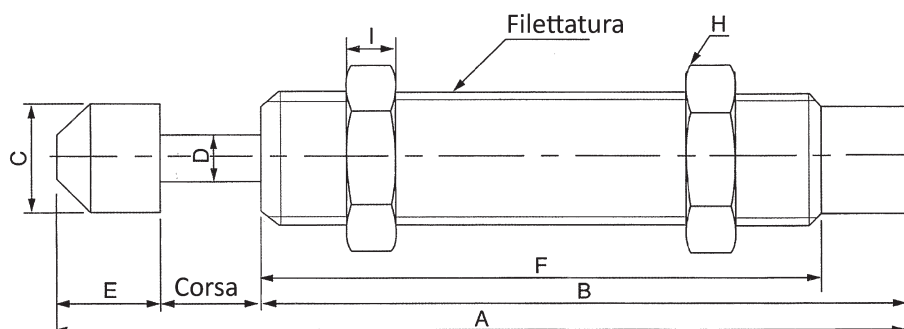

AC-2525

Serie AC autocompensati

Modello	Corsa mm	Filett.	ET N/m	ETC N/H	Me Kg	Vel. max m/sec	Temp. di lavoro °C	Peso g	A	B	C	D	E	F	G	H	I	J	K
AC-2525-1	25	M25 x 1,5	80	54.000	200	4,0	-10 +80	330	155	111	22	8	19	101	-	32	9	-	-
AC-2525-2	25	M25 x 1,5	80	54.000	800	2,5	-10 +80	330	155	111	22	8	19	101	-	32	9	-	-
AC-2525-3	25	M25 x 1,5	80	54.000	1.500	1,0	-10 +80	330	155	111	22	8	19	101	-	32	9	-	-
AC-2540-1	40	M25 x 1,5	120	75.000	300	4,0	-10 +80	430	214	137	22	8	37	117	10	32	9	-	-
AC-2540-2	40	M25 x 1,5	120	75.000	1.200	2,5	-10 +80	430	214	137	22	8	37	117	10	32	9	-	-
AC-2540-3	40	M25 x 1,5	120	75.000	2.000	1,0	-10 +80	430	214	137	22	8	37	117	10	32	9	-	-
AC-2550-1	50	M25 x 1,5	98	90.000	15	4,0	-10 +80	435	239,5	170,5	22	8	19	100	-	32	9	23	11
AC-2550-2	50	M25 x 1,5	98	90.000	40	2,5	-10 +80	435	239,5	170,5	22	8	19	100	-	32	9	23	11
AC-2550-3	50	M25 x 1,5	98	90.000	160	1,0	-10 +80	435	239,5	170,5	22	8	19	100	-	32	9	23	11
AC-2580-1	80	M25 x 1,5	150	120.000	20	4,0	-10 +80	535	336	237	22	8	19	100	-	32	9	23	11
AC-2580-2	80	M25 x 1,5	150	120.000	50	2,5	-10 +80	535	336	237	22	8	19	100	-	32	9	23	11
AC-2580-3	80	M25 x 1,5	150	120.000	200	1,0	-10 +80	535	336	237	22	8	19	100	-	32	9	23	11
AC-3660-1	60	M36 x 1,5	250	120.000	400	4,0	-10 +80	1030	248	162	35,5	10	26	134	17	46	15	-	-
AC-3660-2	60	M36 x 1,5	250	120.000	1.500	2,5	-10 +80	1030	248	162	35,5	10	26	134	17	46	15	-	-
AC-3660-3	60	M36 x 1,5	250	120.000	2.400	1,0	-10 +80	1030	248	162	35,5	1	26	134	17	46	15	-	-

DECELERATORI IDRAULICI SHOCK ABSORBERS

AC-2540

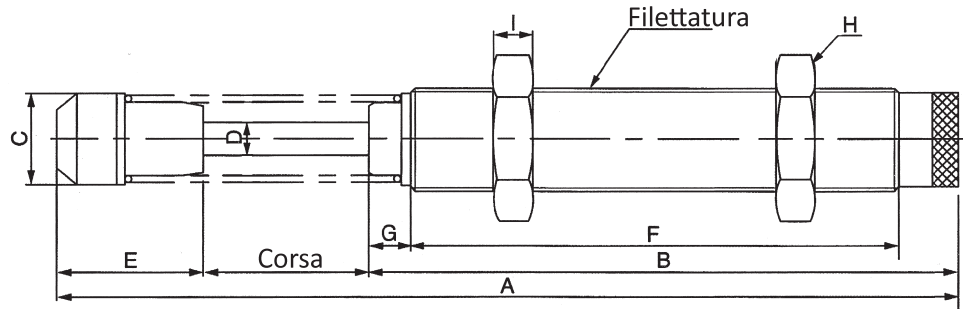

AC-2550

AC-2580

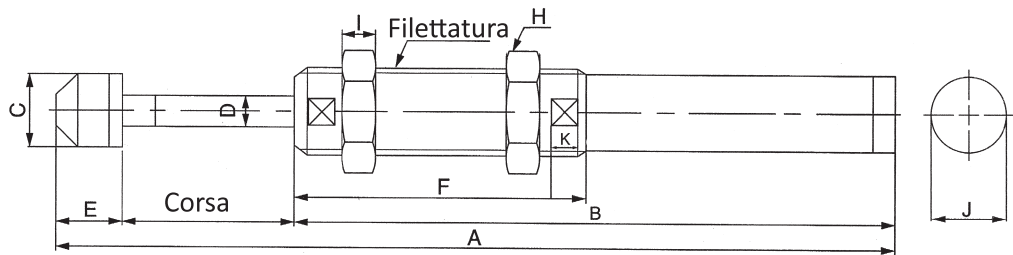

AC-3660

