

# DECELERATORI CJAC

## CJAC SHOCK ABSORBERS

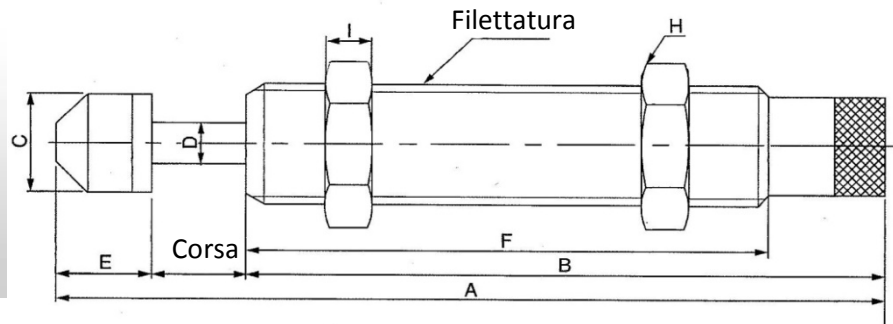

### Serie AD registrabili

Modello	Corsa mm	Filettatura	ET N/m	ETC N/H	Me Kg	Velocità massima di impatto m/sec	Temp. di lavoro °C	Peso g	A	B	C	D	E	F	H	I
AD-1410-N	10	M14 x 1,5	20	25.000	80	3,0	-10 +80	84	-	88,5	-	4	-	72,5	19	5
AD-1410	10	M14 x 1,5	20	25.000	80	3,0	-10 +80	90	109,5	88,5	12	4	11	72,5	19	5
AD-2016-N	16	M20 x 1,5	25	30.000	200	3,5	-10 +80	222	-	117	-	6	-	101	26	7
AD-2016	16	M20 x 1,5	25	30.000	200	3,5	-10 +80	230	148	117	18	6	15	101	26	7
AD-2025-N	25	M20 x 1,5	39	30.000	312	3,5	-10 +80	232	-	117	-	6	-	101	26	7
AD-2025	25	M20 x 1,5	39	30.000	312	3,5	-10 +80	240	157	117	18	6	15	101	26	7
AD-2525-N	25	M25 x1,5	85	54.000	400	3,5	-10 +80	335	-	118,5	-	8	-	101	32	9
AD-2525	25	M25 x1,5	85	54.000	400	3,5	-10 +80	350	162,5	118,5	22	8	19	101	32	9
AD-2530-N	30	M25 x1,5	95	60.000	480	3,5	-10 +80	340	-	118,5	-	8	-	101	32	9
AD-2530	30	M25 x1,5	95	60.000	480	3,5	-10 +80	365	167,5	118,5	22,0	8	19	101	32	9

Applicazione su nastro trasportatore (fonderia)

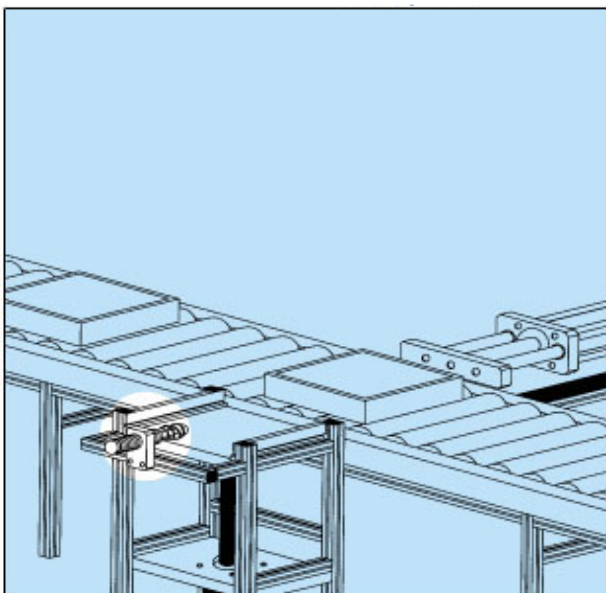

Applicazione su stazione pick & place

